

Pick™ IBO - Compensation Plan Overview

Effective January 1, 2019



The Pick™ Opportunity has been designed to help you build a successful business of your own. Pick™ Independent Business Owners (IBOs) can earn money in five ways:

1. Ride residual commissions based on their current earned position.
2. Monthly personal volume residual commissions based on their downline personal volume.
3. Fast start bonus based on their own qualification.
4. Senior Associate bonus based on their new Level 1 IBO qualification.
5. Monthly bonuses based on their current earned position.

Compensation is earned only when you have a personal volume of 100.

Access your IBO Back Office for details on Pick's monthly promotional bonuses - designed to get new IBOs off to a fast start.

Positions & Qualifications

Starting Position: Every IBO starts as an Associate (A)

Earned Positions:

QA Qualified Associate

100 PV

Personal volume of 100

SA Senior Associate

100 PV  1

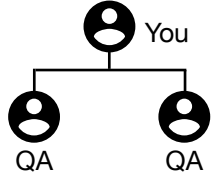

Personal volume of 100
1 Driver, 2 QA legs in L1

EA Executive Associate

100 PV  3

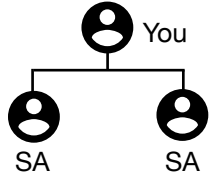

Personal volume of 100
3 Drivers, 2 SA legs in L1

SEA Senior Executive Associate

100 PV  10

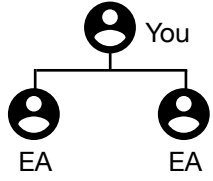

Personal volume of 100
10 Drivers, 2 EA legs in L1

RD Regional Director

100 PV  10

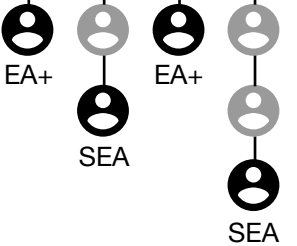

Personal volume of 100
10 Drivers, 2 EA or above legs in L1
1 SEA in 2 separate legs

RVP Regional Vice President

100 PV  10

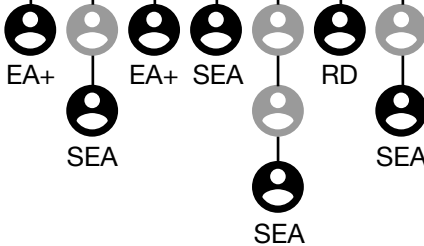

Personal volume of 100
10 Drivers, 2 EA or above legs in L1
1 SEA in 4 separate legs, 1 RD leg

SVP Senior Vice President

100 PV  10

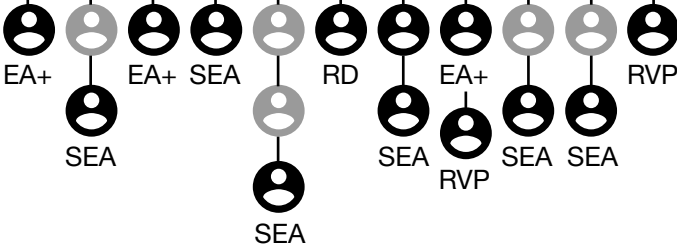

Personal volume of 100
10 Drivers, 3 EA or above legs in L1
1 SEA in 6 separate legs, 2 RVP legs at any level

Only approved and active Drivers count, Drivers are considered active for the first 90 days from approval and then must complete 1 ride during the month to be considered active.

Earnings as a Pick™ IBO are based highly upon the successful acquisition of approved and active Drivers. Individuals will incur expenses in operating their Pick™ business, such as the on-boarding fee and monthly back office fee, as well as other possible operating expenses.

As with any business, earnings and success at Pick™ are not guaranteed but depend primarily on the individual's commitment, persistence and effort. Individuals may not earn income and may lose money as an IBO.

The Pick™ Compensation Plan is subject to change without notice at Pick's discretion and for any reason.

Ride Residual Commissions

Amount paid on each completed ride for a driver in that level if you become qualified to receive the commission based on the chart below.

Level	QA	SA	EA	SEA	RD	RVP	SVP
L0	\$0.25						
L1	\$0.05						
L2	\$0.05	\$0.10					
L3	\$0.05	\$0.10	\$0.12	\$0.15			
L4	\$0.05	\$0.10	\$0.12	\$0.15	\$0.17	\$0.20	
L5	\$0.05	\$0.10	\$0.12	\$0.15	\$0.17	\$0.20	\$0.25

Over time, the majority of your compensation will come from the ride commissions. Driver acquisition is the fuel for your business, creating long-term lasting income and by teaching other people how to do the same thing, you will build residual income for yourself.

Monthly Personal Volume Residual Commissions

Percent paid of the total PV for that level if you become qualified to receive the commission based on the chart below.

Level	QA	SA	EA	SEA	RD	RVP	SVP
L1	1%						
L2	1%	2%					
L3	1%	2%	3%				
L4	1%	2%	3%	4%			
L5	1%	2%	3%	4%	5%	6%	10%

Bonuses

Fast Start Bonus

\$100

Paid if you become qualified as SA within the first 30 days

Senior Associate Bonus

\$50

Paid to the SA or above when a new Level 1 IBO becomes qualified as SA within their first 30 days

Monthly Car Bonus



RD - \$500
RVP - \$600
SVP - \$750

Qualified positions RD and above will receive a monthly car bonus for a qualified car. Apply for your bonus within the Pick Money app.